

BOD/COD SENSOR

BL SERIES



FEATURES & BENEFITS

- Affordable real-time BOD/COD monitoring
- Multiple wavelength sensor uses UV LED technology for superior measurement performance
- Bypass style sensor with multiple flow cell selections to meet application demands
- Operator friendly, low maintenance UV LED design
- Reagent free optical measurements
- Simple to install and operate

MUNICIPAL DRINKING WATER
MUNICIPAL WASTEWATER
INDUSTRIAL PROCESS WATER
INDUSTRIAL WASTEWATER

WATER QUALITY
MONITORING
SOLUTIONS

REAL-TIME MONITORING SOLUTION

BOD/COD Sensor

Real Tech's bypass BOD/COD sensor provides affordable real-time measurement of organic matter in water or wastewater. Designed to meet the needs of many monitoring applications, the BL series offers multiple flow cell designs and sensor path length selections to meet the desired measurement range.

Controllers and Accessories

Our innovative modular product platform ensures our clients gain the real-time water quality monitoring system that meets their specific demands and budget. With multiple controller and accessory options available such as automatic chemical cleaning systems that lower maintenance while improving system performance, Real Tech provides a total solution for all of your unique water quality needs.

Liquid Ai® Compatible

Our Liquid Ai® data services complement our real-time quality monitoring systems. Calibration Health Monitoring ensures accuracy and reliability are maintained so our clients can have the utmost confidence in their results, while our Remote Monitoring platform enables access to data anywhere, anytime.

MEASUREMENT PRINCIPLE

Real Tech's BOD/COD sensor provides superior measurement performance across multiple wavelengths of light using UV LEDs. Many compounds absorb light in the UV-VIS spectrum including organic compounds. The sensor measures organics in a multi-dimensional way that results in improved correlations to aggregate organics water quality parameters, such as BOD, COD and TOC. This also allows the sensor to be able to detect changes in the composition of organics independently of their concentration. Real Tech's innovative BOD/COD sensor is advancing wastewater management.

REALTECH
INC.



BOD/COD SENSOR SPECIFICATIONS

CHARACTERISTIC	TECHNICAL DATA	
Model Series	1000 series	2000 series
Path Length	0.5, 1, 2, 4, 10 mm	1, 2, 4, 8 mm
Parameters	BOD, COD, TOC	
Range	Depends on model selected. Refer to range chart.	
Units	mg/L	
Sampling Time	30 seconds	
Calibration	Factory calibrated. Field adjustment of calibration is possible.	
Cleaning	In-situ chemical cleaning makes cleaning quick and easy. Automatic chemical cleaning is optional.	
Self-Diagnostics	Detection and diagnosis of internal system fault	
Alarms	Dry contact terminals allow for operator configurable alarms for: high and low set points, low lamp output, leaks, system fault, etc.	
Humidity Control	Humidity sensor with large plug-in regenerating desiccant system	
Wavelength	Multiple wavelengths	
Light Source	UV LED	
Flow Rate	500-1000 mL/min	300-1000 mL/min
Pressure Rating	85 PSI maximum	20 PSI maximum
Fluid Connections	3/8" OD tube push-in fittings	1/4" OD tube push-in fittings
Wetted Materials	Kynar, FEP, Quartz, SS316L, Viton	Kynar, Polyethylene, Quartz, SS 316L, Viton
Electrical/Comm.	From controller	
Ambient Temp.	0 to 45°C (32 to 113°F)	
Water Temp.	0 to 90°C (32 to 194°F) at 21°C (69.8°F) Ambient temperature	
Enclosure	NEMA 4X, wall mountable	
Weight	22 lb	
Dimensions	17"H x 14.25"W x 7.5"D	
Warranty	2-year limited warranty (Extended care packages available)	

* Technical Specifications are subject to change without notice.

* Water temperature range based on material compatibility only. Contact Real Tech to verify application.

DIMENSIONS

The BOD/COD sensor is a bypass cabinet instrument installed directly on a wall, railing or system backboard. Sample is supplied to the sensor from either a pressurized source or from an open-channel using an accessory pumping system.

DIMENSIONS FOR 1000 & 2000 SERIES MODELS

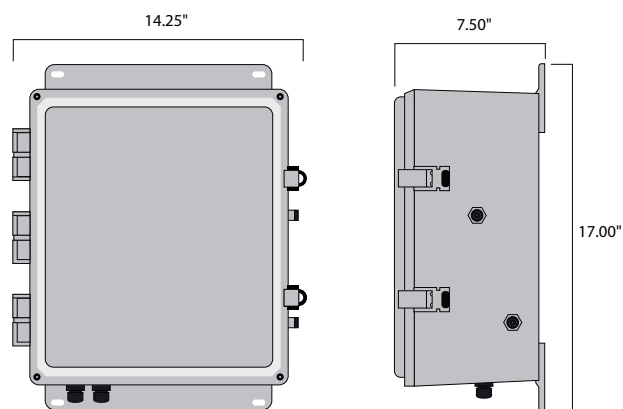

SENSOR SELECTION

MODEL SERIES	DESCRIPTION
1000	Ideal for closed loop, high pressure or high solids wastewater monitoring applications
2000	Ideal for general water monitoring applications

SENSOR MODELS & RANGE

Includes BOD/COD sensor, flow cell, calibration bottle and dehumidifier. Controller and accessories sold separately.

Measurement ranges are estimations based on previous field data, and may vary based on plant specific details. Full measurement range may be greater than the ranges stated in the table below, although accuracy may be significantly reduced outside these stated ranges.

Please contact Real Tech for your application specific demands.

MUNICIPAL

MODEL#	PATH LENGTH	BOD (mg/L)	COD (mg/L)	TOC (mg/L)
BL1005	0.5 mm	0 - 6000	0 - 14,000	0 - 3500
BL1010	1 mm	0 - 3000	0 - 7000	0 - 1750
BL1020	2 mm	0 - 1500	0 - 3500	0 - 875
BL1040	4 mm	0 - 750	0 - 1750	0 - 440
BL1100	10 mm	0 - 300	0 - 700	0 - 175
BL2010	1 mm	0 - 3000	0 - 7000	0 - 1750
BL2020	2 mm	0 - 1500	0 - 3500	0 - 875
BL2040	4 mm	0 - 750	0 - 1750	0 - 440
BL2080	8 mm	0 - 375	0 - 875	0 - 220

DAIRY

MODEL#	PATH LENGTH	BOD (mg/L)	COD (mg/L)	TOC (mg/L)
BL1005	0.5 mm	0 - 20,000	0 - 50,000	0 - 12,500
BL1010	1 mm	0 - 10,000	0 - 25,000	0 - 6250
BL1020	2 mm	0 - 5000	0 - 12,500	0 - 3125
BL1040	4 mm	0 - 2500	0 - 6250	0 - 1560
BL1100	10 mm	0 - 1000	0 - 2500	0 - 625
BL2010	1 mm	0 - 10,000	0 - 25,000	0 - 6250
BL2020	2 mm	0 - 5000	0 - 12,500	0 - 3125
BL2040	4 mm	0 - 2500	0 - 6250	0 - 1560
BL2080	8 mm	0 - 1250	0 - 3125	0 - 780

BEVERAGE

MODEL#	PATH LENGTH	BOD (mg/L)	COD (mg/L)	TOC (mg/L)
BL1005	0.5 mm	0 - 16,000	0 - 48,000	0 - 12,000
BL1010	1 mm	0 - 8000	0 - 24,000	0 - 6000
BL1020	2 mm	0 - 4000	0 - 12,000	0 - 3000
BL1040	4 mm	0 - 2000	0 - 6000	0 - 1500
BL1100	10 mm	0 - 800	0 - 2400	0 - 600
BL2010	1 mm	0 - 8000	0 - 24,000	0 - 6000
BL2020	2 mm	0 - 4000	0 - 12,000	0 - 3000
BL2040	4 mm	0 - 2000	0 - 6000	0 - 1500
BL2080	8 mm	0 - 1000	0 - 3000	0 - 750

BREWERY

MODEL#	PATH LENGTH	BOD (mg/L)	COD (mg/L)	TOC (mg/L)
BL1005	0.5 mm	0 - 16,000	0 - 48,000	0 - 12,000
BL1010	1 mm	0 - 8000	0 - 24,000	0 - 6000
BL1020	2 mm	0 - 4000	0 - 12,000	0 - 3000
BL1040	4 mm	0 - 2000	0 - 6000	0 - 1500
BL1100	10 mm	0 - 800	0 - 2400	0 - 600
BL2010	1 mm	0 - 8000	0 - 24,000	0 - 6000
BL2020	2 mm	0 - 4000	0 - 12,000	0 - 3000
BL2040	4 mm	0 - 2000	0 - 6000	0 - 1500
BL2080	8 mm	0 - 1000	0 - 3000	0 - 750

MEAT PROCESSING

MODEL#	PATH LENGTH	BOD (mg/L)	COD (mg/L)	TOC (mg/L)
BL1005	0.5 mm	0 - 12,000	0 - 20,000	0 - 5000
BL1010	1 mm	0 - 6000	0 - 10,000	0 - 2500
BL1020	2 mm	0 - 3000	0 - 5000	0 - 1250
BL1040	4 mm	0 - 1500	0 - 2500	0 - 600
BL1100	10 mm	0 - 600	0 - 1000	0 - 250
BL2010	1 mm	0 - 6000	0 - 10,000	0 - 2500
BL2020	2 mm	0 - 3000	0 - 5000	0 - 1250
BL2040	4 mm	0 - 1500	0 - 2500	0 - 625
BL2080	8 mm	0 - 750	0 - 1250	0 - 310

PULP & PAPER

MODEL#	PATH LENGTH	BOD (mg/L)	COD (mg/L)	TOC (mg/L)
BL1005	0.5 mm	0 - 1400	0 - 4000	0 - 1000
BL1010	1 mm	0 - 700	0 - 2000	0 - 500
BL1020	2 mm	0 - 350	0 - 1000	0 - 250
BL1040	4 mm	0 - 175	0 - 500	0 - 125
BL1100	10 mm	0 - 70	0 - 200	0 - 50
BL2010	1 mm	0 - 700	0 - 2000	0 - 500
BL2020	2 mm	0 - 350	0 - 1000	0 - 250
BL2040	4 mm	0 - 175	0 - 500	0 - 125
BL2080	8 mm	0 - 90	0 - 250	0 - 60

* Stated ranges are approximate, dependent on site and application - contact Real Tech to confirm model selection.

* TSS measurement output possible, contact Real Tech to confirm.

CONTROLLERS

Controllers include proprietary inputs for Real Tech sensors and accessories.

PRODUCT #	NAME	DESCRIPTION
S--229005	Real Controller Lite	Wall mounted controller with 4-line x 20-character back lit LCD display. Includes modbus RTU (RS485)
S-169000	Real Controller	Wall mounted controller with 4-line x 20-character back lit LCD display. Includes modbus RTU (RS485), 1 channel of 4-20 mA out and digital I/O module
S-11TPC	Real Controller Pro	Wall mounted controller with 12.1" colour LCD touch panel PC interface (PC inside cabinet model). Includes Modbus TCP
S-11TPCD	Real Controller Pro	Wall mounted controller with 12.1" colour LCD touch panel PC interface (PC external on door model). Includes Modbus TCP

ACCESSORIES

PRODUCT #	NAME	DESCRIPTION
UVT-078130	Real Clean System I	Automatic chemical cleaning system for use with 2000 series models
UVT-079121	Pump Clean System I	Self-priming pump and automatic chemical cleaning for use with 2000 series models
S-229035	Pump Clean Pro System (pressurized)	For high solids sample water, automatic chemical cleaning and pumping system for up to 25' vertical lift or 100' horizontal in pressurized installation (no air compressor)
S-229036	Pump Clean Pro System (non-pressurized)	For high solids sample water, automatic chemical cleaning and pumping system for up to 25' vertical lift or 100' horizontal in non-pressurized/ open channel installation (no air compressor)
S-178121	Dual Feed II	Dual feed option includes Digital I/O module for use with controllers

BACKBOARDS & ASSEMBLY

Pre-wired and plumbed solution assembled and mounted on backboard with or without stand.

PRODUCT #	DESCRIPTION
S-169033	46" x 46" Industrial grade black plastic mounting backboard and assembly
S-179034	24" x 60" Industrial grade black plastic mounting backboard and assembly
S-179036	46" x 46" Industrial grade black plastic mounting backboard with stand and assembly
S-179035	24" x 60" Industrial grade black plastic mounting backboard with stand and assembly

Real Tech Inc.

1150 Champlain Court,
Whitby, Ontario L1N 6K9 Canada
TF: 1.877.779.2888 T: 1.905.665.6888
info@realtechwater.com

