

Real UV254 Sensor

ML SERIES



Features & Benefits

- Affordable real-time organics monitoring solution
- Dual wavelength sensor (254 nm and 550 nm)
- Wastewater to high purity measurement ranges
- Operator friendly, low maintenance design
- Quick and simple optical measurements
- Reagent free operation

Measurement Principle

The sensors utilize light at 254 and 550 nm wavelengths. Many organic compounds, specifically aromatic organics, absorb light at 254 nm while interfering compounds are compensated for at 550 nm. Benefiting from Real Tech's innovative Ortho-Beam and Split-Sense Pro technologies, lamp drift and fluctuations are compensated for, providing an accurate and stable output overtime. ML series sensor parameters include UV254, UVT, TOC, DOC, BOD, COD, colour and permanganate, dependent on application and industry.

APPLICATIONS

- Municipal Drinking Water
- Municipal Wastewater
- Industrial Process Water
- Industrial Wastewater

Versatile and Configurable

ML SERIES UV254 SENSORS

The ML series sensors provide affordable real-time measurement of organic matter in water or wastewater. Designed to meet the needs of any monitoring application, the series offers multiple sensor path length selections for the desired measurement range.

CONTROLLERS AND ACCESSORIES

Real Tech's modular approach allows a system to be configured around the ideal sensor with controller options and various accessory products, including automatic chemical cleaning systems that lower maintenance while improving system performance and dilution systems that extend the measurement range for highly concentrated wastewaters. We can truly meet the physical demands of any installation, wastewater or high purity, to ensure reliable, continuous operation.

REAL-TIME DATA

With the right sensor and hardware configuration, we then build a custom calibration for the aggregate organics parameter(s) or compounds of interest.

Specifications

CHARACTERISTIC	TECHNICAL DATA								
Model	ML2010	ML2020	ML2040	ML2100	ML3000	ML4050	ML4100	ML4150	ML4250
Path Length	1 mm	2 mm	4 mm	10 mm	10 mm x 20 mm	50 mm	100 mm	150 mm	250 mm
Technology	Split-Sense Pro			Ortho -Beam		Split-Sense Pro			
Parameters	BOD, COD, TOC, DOC, UV254, UVT, colour, permanganate								
Units	Parameter specific (mg/L, cm ⁻¹ , % or PCU)								
Accuracy	± 0.5% FS								
Sampling Time	10 seconds								
Calibration	In-situ zeroing to any sample with known UVT. No further calibration required.								
Cleaning	In-situ chemical cleaning makes cleaning quick and easy. Automatic chemical cleaning is optional.								
Self-Diagnostics	Detection and diagnosis of internal system fault								
Alarms	Dry contact terminals allow for operator configurable alarms for: high and low set points, low lamp output, leak detected, system fault, etc.								
Humidity Control	Humidity sensor with large plug-in regenerating desiccant system								
Wavelength	253.7 nm and 550 nm								
Light Source	Low-pressure mercury UV lamp and LED								
Lamp Life	2 years								
Enclosure	NEMA 4, wall mountable								
Flow Rate	300-1000 mL/min								
Pressure Rating	20 PSI								
Fluid Connections	1/4" OD tube push-in fittings								
Electrical/Comm.	From controller								
Storage Temp.	-20 to 60°C (-4 to 140°F)								
Operating Temp.	0 to 45°C (32 to 113°F)								
Weight	22 lbs				24 lbs				
Dimensions	17"H x 14.25"W x 7.5"D				17.75"H x 15.5"W x 6.75"D				
Warranty	2-year limited warranty (Extended care packages available)								

* Technical Specifications are subject to change without notice.

Dimensions

ML series sensors are bypass cabinet instruments installed directly on a wall, railing or system backboard. Sample is supplied to the sensor from either a pressurized source or from an open-channel using an accessory pumping system.

ML2000 SERIES AND ML3000 MODELS

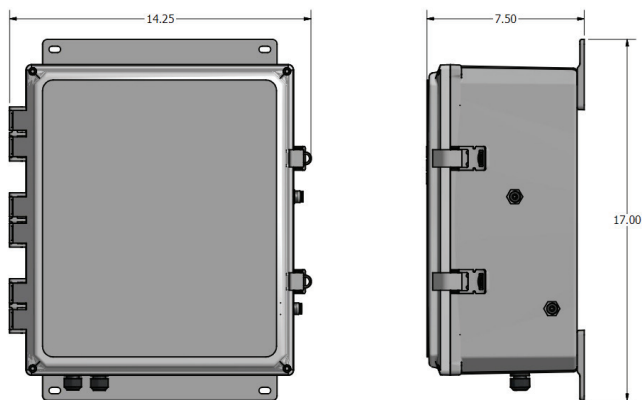

ML4000 SERIES MODELS

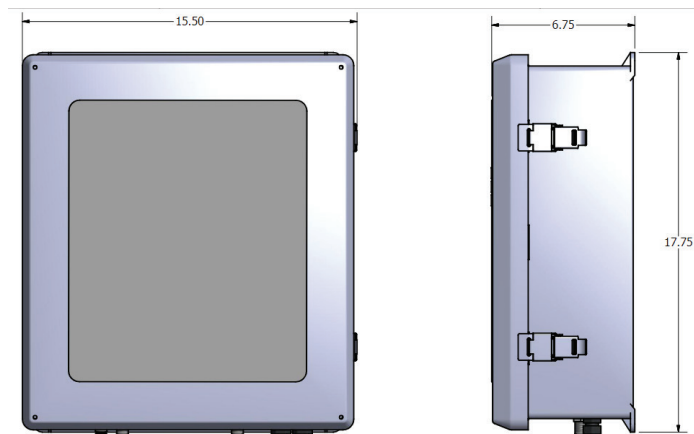

Models & Range

ML series models include UV254 sensor, flow cell, calibration bottle and dehumidifier. Controller and accessories sold separately.

MODEL#	PATH LENGTH	UV254 (cm ⁻¹)	UVT (%)	TOC (mg/L)	DOC (mg/L)	COLOUR (PCU)	BOD (mg/L)	COD (mg/L)
ML2010	1 mm	0 - 20	0 - 100	0 - 1200	0 - 800	0 - 6000	0 - 1500	0 - 3000
ML2020	2 mm	0 - 10	0 - 100	0 - 600	0 - 400	0 - 3000	0 - 750	0 - 1500
ML2040	4 mm	0 - 5	0 - 100	0 - 300	0 - 200	0 - 1500	0 - 375	0 - 750
ML2100	10 mm	0 - 2	1 - 100	0 - 120	0 - 80	0 - 600	0 - 150	0 - 300
ML3000	10 x 20 mm	0 - 1	10 - 100	0 - 60	0 - 40	0 - 300	0 - 75	0 - 150
ML4050	50 mm	0 - 0.4	40 - 100	0 - 24	0 - 16	0 - 120	0 - 30	0 - 60
ML4100	100 mm	0 - 0.2	63 - 100	0 - 12	0 - 8	0 - 60	0 - 15	0 - 30
ML4150	150 mm	0 - 0.13	74 - 100	0 - 8	0 - 5.3	0 - 40	0 - 10	0 - 20
ML4250	250 mm	0 - 0.08	83 - 100	0 - 4.8	0 - 3.2	0 - 24	0 - 6	0 - 12

* Stated ranges are approximate, dependent on industry, site and application - contact Real Tech to confirm model selection

* Range for permanganate is site specific, contact Real Tech for details

* Approximation of colour measurement based on UV254

* Higher maximum range possible with use of Dilution System option

Controllers

PRODUCT #	NAME	DESCRIPTION
S-169000	Real Controller	Wall mounted controller with 4-line x 20-character back lit LCD display for sensors
S-11TPC	Smart Sense Controller	Wall mounted controller with touch panel PC interface and Smart Sense software for sensors (PC inside cabinet model)
S-11TPCD	Smart Sense Controller	Wall mounted controller with touch panel PC interface and Smart Sense software for sensors (PC external on door model)

Accessories

PRODUCT #	NAME	DESCRIPTION
UVT-078130	Real Clean System I	Automatic chemical cleaning system for use with 2000 and 3000 series models
UVT-118010	Real Clean System II	Automatic chemical cleaning system for use with 4000 series models
UVT-079121	Pump Clean System I	Self-priming pump and automatic chemical cleaning for use with 2000 and 3000 series models
UVT-129122	Pump Clean System II	Self-priming pump and automatic chemical cleaning for use with 4000 series models
S-159124	Air Purge Clean System I	Automatic chemical cleaning, air purge and pump (vertical lift less than 8 ft and pumping distance less than 25ft)
S-179125	Air Purge Clean System II	Automatic chemical cleaning, air purge and booster pump (vertical lift exceeds 8ft or pumping distance exceeds 25 ft)
S-179126	Air Purge Clean System III	Automatic chemical cleaning and air purge. Client supplies pump or water is pressurized
S-169092	Dilution System I	Dilution system, automatic chemical cleaning, air purge and pump (vertical lift less than 8 ft and pumping distance less than 25ft)
S-179093	Dilution System II	Dilution system, automatic chemical cleaning, air purge and booster pump (vertical lift exceeds 8ft or pumping distance exceeds 25 ft)
S-179094	Dilution System III	Dilution system, automatic chemical cleaning and air purge. Client supplies pump or water is pressurized



Siam Pollutek Co., Ltd

40/25 Soi Wachiratham-satit 8, Sukmvit 101/1, Bangna, Bangkok 10260
Tel 02- 7478234, Fax 02-7477566, E-mail : info@siampollutek.com
Web : www.siampollutek.com, Line ID : siam.pollutek



REALTECHWATER.COM